



50Hz

Designed for light weight, excellent performance, low energy consumption, and easy maintenance, PRORIL submersible handy pumps serve a wide range of pumping applications on utility, construction, industrial, and municipal job sites.

Handy and Residue Pump

SAVVY JUMBO 300/600

Handy Pump



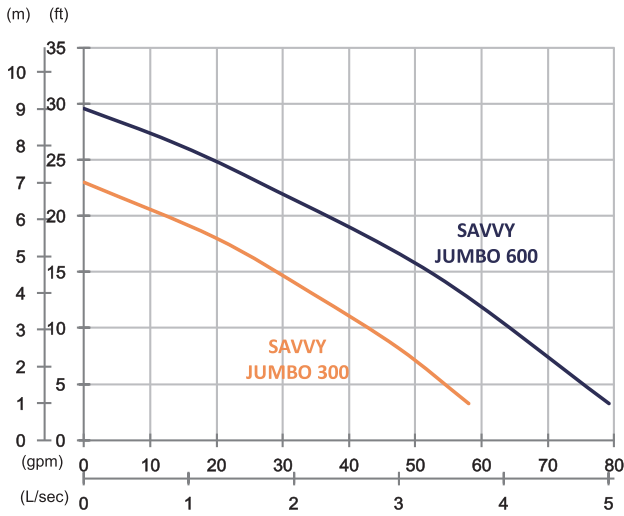

	SAVVY JUMBO 300	SAVVY JUMBO 600
OUTPUT	0.25 kW (0.33 HP)	0.55 kW (0.75 HP)
OUTLET	2" (50 mm)	2" (50 mm)
SOLID PASSAGE	35 mm	35 mm
Weight	4.2 kg	6 kg
HEAD	Rated: 4 m Max: 7 m	Rated: 7 m Max: 9 m
FLOW	Rated: 2.2 L/s Max: 3.7 L/s	Rated: 1.7 L/s Max: 5 L/s

Pump Type		Electric Submersible Pumps
Motor	Phase	1-Phase
	Type	Induction Motor
	Poles	2 Pole (2850 rpm)
	Insulation	Class F
	Protector	Miniature Thermal Protector
	Starter	Capacitor-Run
Lubricant		Food Grade (ISO VG115)
Specs.	Impeller Type	Vortex
	Shaft Seal	Single Mechanical Seal
		Ceramic/Carbon
	Bearings	C3 Shielded ball bearings
	Cable	H05RN-F
10 m or longer upon request		
Materials	Pump Casing	Synthetic Polymers
	Impeller	Synthetic Polymers
	Motor Frame	Stainless Steel
	Motor Shaft	Stainless Steel
Max. Liquid Temperature		40°C (104°F)
Max. Submersion Depth		10 m (33 ft)
pH Range		pH 5 - pH 8

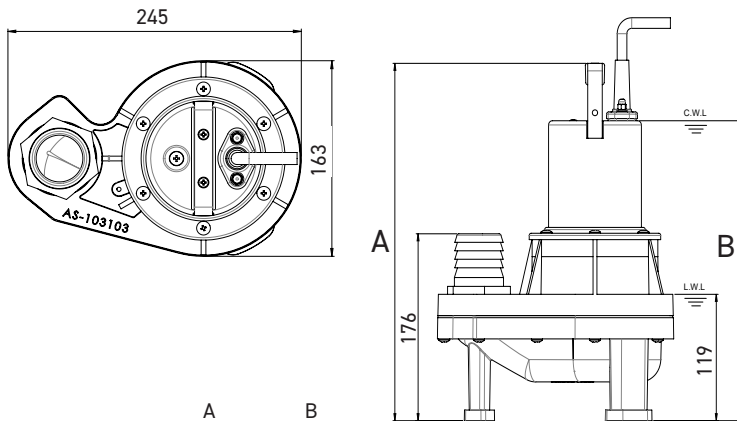

	A	B
SAVVY 300	337	283
SAVVY 600	372	317

unit : mm
C.W.L : Continuous running water level
L.W.L : Lowest running water level